



Teachers' Notes

Curricular links to Health Education 5-14 National Guidelines and RSE Guidelines

Attainment outcome: Taking responsibility for health

LEVEL A

STRAND	ATTAINMENT TARGET	RSE GUIDELINES
Physical health This strand explores physical factors in relation to our health and looking after ourselves.	Show an awareness of simple ways of keeping safe.	Street furniture.
Social health This strand explores the interaction of the individual, the community and the environment in relation to health and safety.	Show simple ways of avoiding incidents e.g. crossing the road safely.	Road Skills – Crossing the road safely.

Teaching Background Information

- ➔ If your school is in a rural area and you do not have a pelican crossing, you may still feel that this lesson is worthwhile for your pupils.
- ➔ 'Pelican crossing' comes from **PE**destrian **LI**ght **CON**trolled crossing.
- ➔ A 'Toucan' crossing is similar to a pelican crossing but with two differences:
 - ➔ There is a cycle way crossing as well as a pedestrian path (hence Two Can Cross!).
 - ➔ There is no flashing amber light for motorists or flashing green man for pedestrians.



Useful Websites

www.hedgehogs.gov.uk/arrivealive/walking/walking2.htm

Suggested Lesson Plan



Aims

- ➔ To show the pupils how to use a pelican crossing.

Learning Outcomes

- ➔ Understand how to use a pelican crossing.



Resources

- ➔ Worksheet A6a – Using a Pelican Crossing.
- ➔ Photos of zebra crossing and pelican crossing.
- ➔ Glossary.
- ➔ Word Flashcards.
- ➔ A2 "Arrive Alive" poster – Walking (DfT).

Suggested Timing

- ➔ 30 minutes.

Suggested Development of Lesson

- ➔ Recap the safe crossing procedures from the previous activities.
- ➔ Ask the children if they know of safe places to cross the road. Hopefully someone will come up with zebra crossing and also a pelican crossing although they may not know what it is called.
- ➔ Show pupils the photo of the zebra crossing and revise the importance of holding hands with a responsible adult.
- ➔ Ask the children if anyone knows what a pelican crossing is.
- ➔ Explain that a pelican crossing has traffic lights to stop the cars and a red and a green man to tell the pedestrians when it is safe to cross. Discuss the photo of the pelican crossing.



Suggested Lesson Plan

- ➔ Go over the procedure for using a pelican crossing with them:
 - ➔ Holding hands with an adult, walk up to the crossing.
 - ➔ Press the button on the box by the crossing. The sign lights up 'WAIT'.
 - ➔ Look at the far side of the crossing where the red man will be lit up. This tells us that it is NOT safe to cross.
 - ➔ Wait until the green man is lit.
 - ➔ Look both ways to make sure the traffic has stopped. This is very important.
 - ➔ Cross straight over the crossing still holding hands. Keep checking the traffic as you cross.
 - ➔ The flashing green man means do not start to cross, but carry on if you have started.

- ➔ Once you are happy they have understood the main concepts:

red man : stop

green man : cross when it is safe and the traffic has stopped

distribute Worksheet A6a.

- ➔ Go over the sheet ensuring the children understand what to do and give them time for completion.

Assessment

- ➔ Correct completion of Worksheet A6a.

Curricular Links

- ➔ English Language – Talking in groups.
- ➔ English Language – Listening in groups.

Follow-up/Homework Activities

- ➔ Safety Street CD-ROM – See Safety Street sheet for details (on following page).
- ➔ Play act crossing the road at a pelican crossing.
- ➔ If you have access to a pelican crossing near the school then a visit to practise using one would be very beneficial.

Safety Street Primary 1 and 2

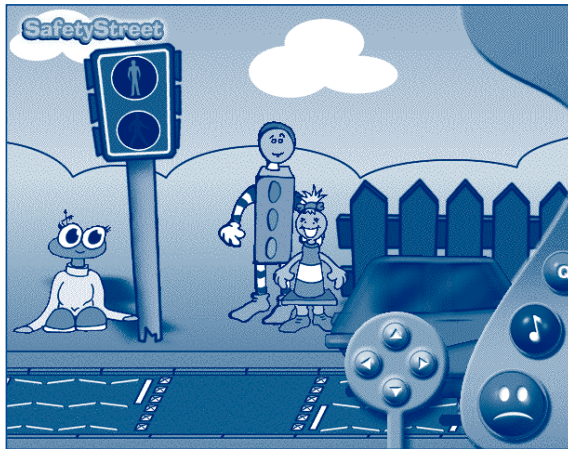
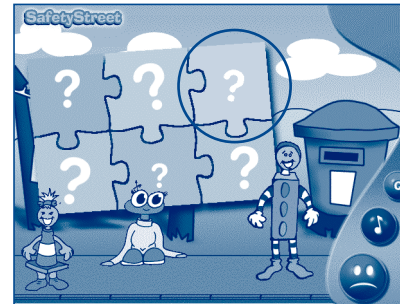

1. Use the green arrow buttons to move the alien across to the crossing and down to the kerb, where the alien stops.

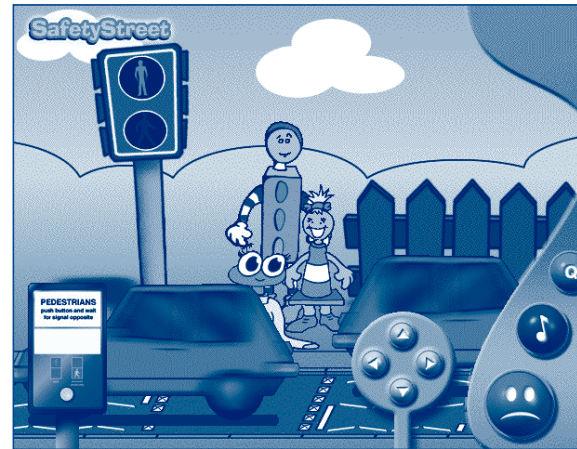

2. The button will appear at the bottom left corner. Click on the yellow button. 'WAIT' appears.

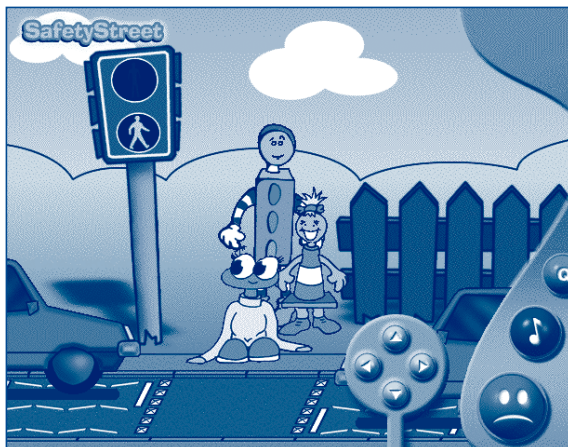

3. Wait for the traffic to stop and the green man to appear.

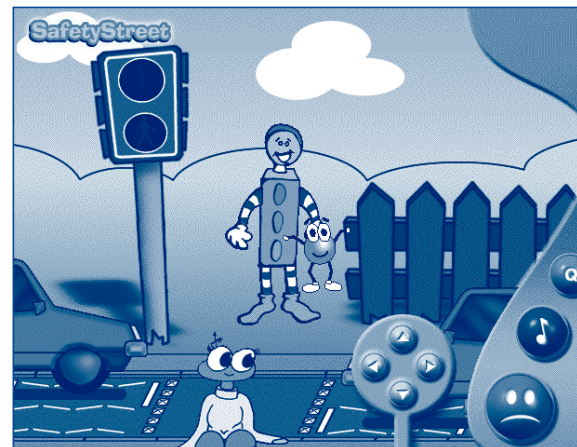

4. Move the alien across the road using the down button BEFORE the green man disappears.

Worksheet A6a Using a Pelican Crossing

Name:

Date:

TASK 1. Colour the red man red in the picture below.



The red man means stop



2. Colour the green man green in the picture below.



The green man means cross when it is safe

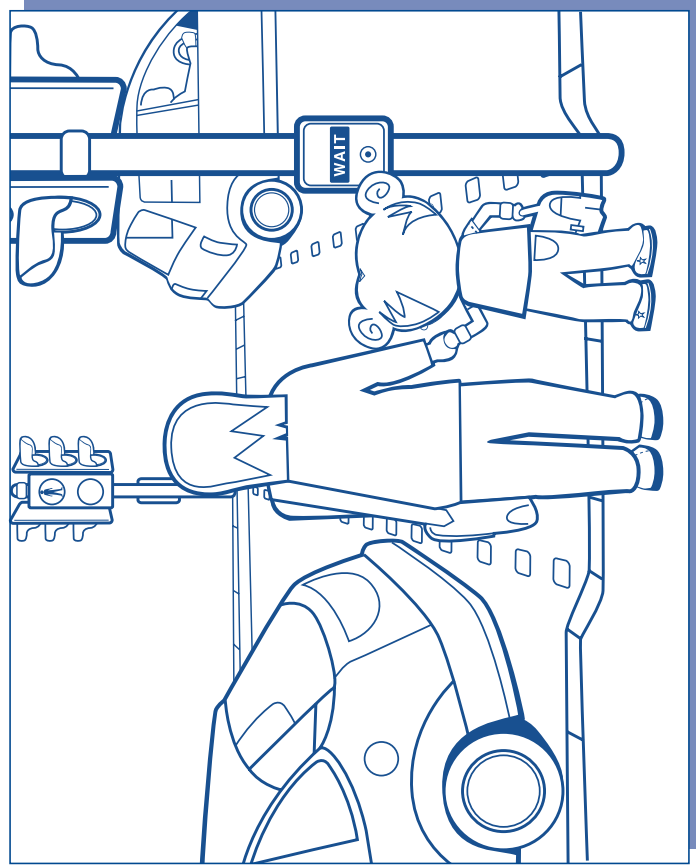

EXTRA Colour in the pictures.

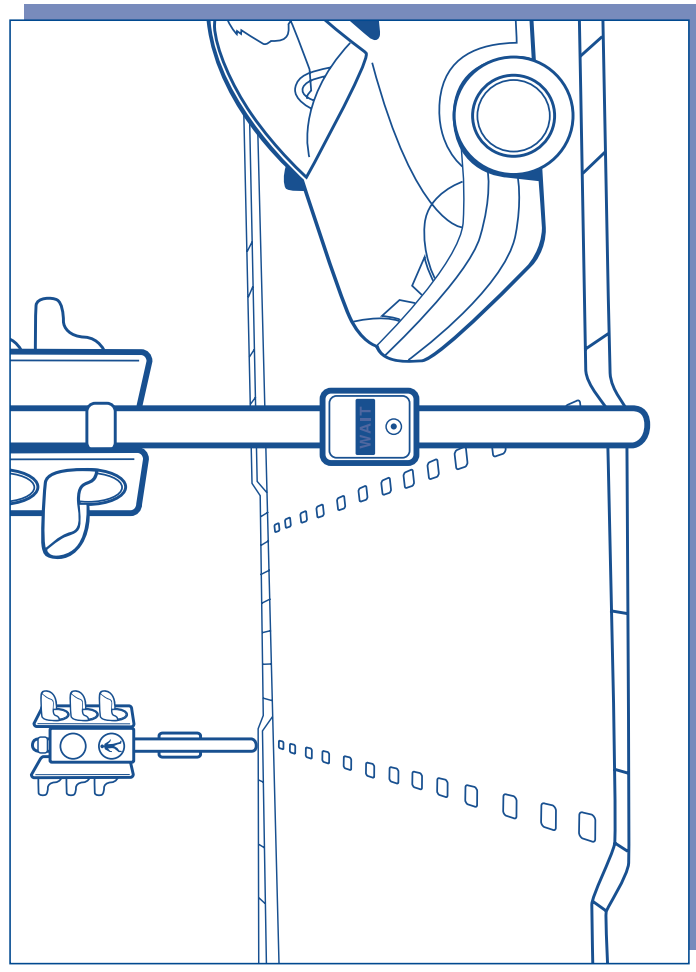

3. Draw someone crossing the road.